



HYDRAFORK

MODEL 5012



*Durable to Last Generations,
Innovative to Meet Your Diverse Grinding Needs*



402-528-3861



mightygiant@mightygiant.com



www.mightygiant.com



HYDRAFORK

MODEL 5012

Model 5012	
Engine Options	New CAT or John Deere Engine w/ extended warranty
Horsepower	Up to 800 HP
Fan	Optional Reversing Fan
Clutch	Twin Disc SP318 or Fluid Coupling
Hammer	3/8" or 1/2"
Number of Hammers	Up to 96
Mill	26"x48", 28"x50", or 28"x56"
Mill Bearing Size	3 15/16" Pillow Block
Mill Hammer Pins	6 Pins - 1 1/4" Diameter
Tub Size	9' or 10' Interior
Tub Drive	Single Drive Hydraulic Motor Drive w/ No. 2100 Heavy Duty, Self Adjusting Chain
Elevator Dimensions	24" Wide x 27' Hydraulic Rigid with Swing 24" Wide x 25' Hydraulic Folding
Elevator Drive	Top Drive via Hydraulic Motor
Discharge Auger	14" Right Hand Auger
Dimensions	Length: 40' 10" Height: 13'9" Width: 9' Tub: 11'4" / 10' Tub: 12' 2"
Weight	Approximately 45,000 pounds

The Mighty Giant Model 5012 is a production model grinder with a hydraulic fork as standard equipment, allowing the operator to control the entire grinder from the relative comfort of the grinder's cab. With a multi-function remote control system, the 27' long, top-driven, elevator swings from side to side, for ease of use in grinding into piles, buildings or trucks.

The Mighty Giant comes equipped with your choice of Caterpillar or John Deere engines up to 800 HP, featuring 5-Year extended engine warranty coverage.

Standard on every Mighty Giant - from the PTO Model to the Hydrafork - is the hydraulic opening tub for easy access to the mill, hammers and screens - eliminating the need to climb in and out of the tub.

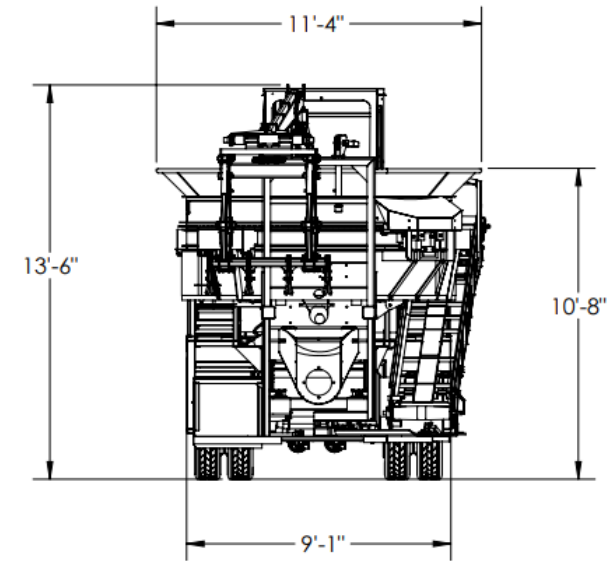

FEATURES

- Tub opens hydraulically for servicing and changing screens.
- Tub Operation is controlled by Plus 1 governor.
- Tub is hydraulically chain-driven with variable speed and reverse.
- Elevator drives from the top with rubber lagged pulley .
- Hydraulically raise & lower discharge elevator..
- Trouble-free 14" High-capacity discharge auger.
- Designed for use with all types of forage.
- Built on a tube frame w/ tandem axle chassis and 25K Air Ride.
- Deluxe Cab with heat and air conditioning.

