



WOOD MODEL 4115

Since
1929



You get more than 70 years of hands-on, in-the-field experience in every Mighty Giant we build.

*Durable to Last Generations,
Innovative to Meet Your Diverse Grinding Needs*

☎ 402-528-3861

✉ mightygiant@mightygiant.com



www.mightygiant.com



WOOD MODEL 4115

Model 4115	
Hammer	1/4", 3/8", 1/2" or 3/4" thick
Number of Hammers	84 to 96
Mill	26" x 48" or 28" x 56"
Mill Bearing Size	522 Mill Bearing
Mill Hammer Pins	6 Pins - 1 1/4" Diameter
Tub Size	10' Interior
Tub Drive	Single or Dual Hydraulic Drive Motor w/ No. 2100 Heavy Duty Chain
Elevator Dimensions	24" x 25' Hydraulic Fold Over the Tub w/ swing
Elevator Drive	Hydraulic Motor
Discharge Auger	16" Right Hand Auger
Dimensions	Length: 22'5" - 43' 6"
	Width: 12' 2"
	Height: 12'6"
Weight	Approximately 22,420 pounds

The Mighty Giant Model 4115 is a heavy duty, commercial tub grinder, built for the wood and mulch industries. It features an Electronically controlled, variable speed, Hydraulic Driven Tub and a hydraulically driven, swinging, stacking elevator. Remote controlled tub and elevator functions are optional for operator convenience. The Mighty Giant mill is a free swinging hammer mill for a higher quality finished product.

A 16" discharge auger under the mill feeds the top-driven elevator, allowing trouble free operation and less mess under the grinder.

Standard on every Mighty Giant - from the PTO Model to the Hydrafork - is the hydraulic opening tub for easy access to the mill, hammers, and screens - without having to climb in and out of the tub.

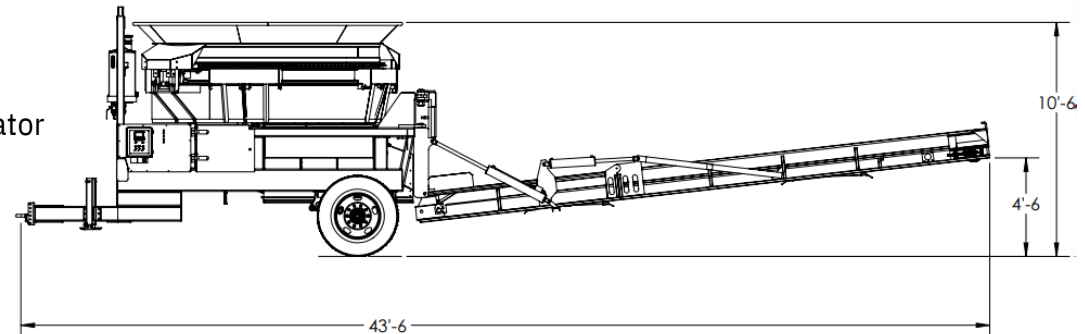
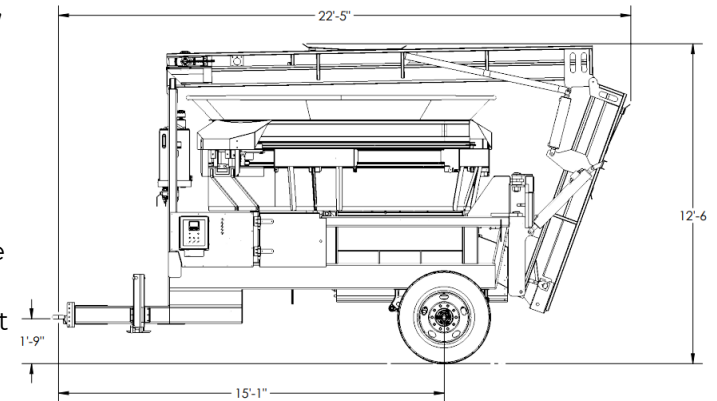
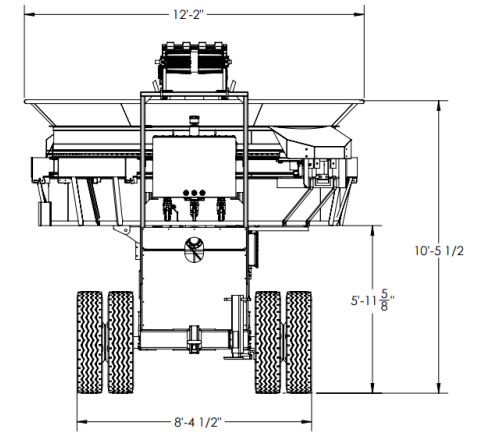

FEATURES

- Tub opens hydraulically for servicing and changing screens
- Tub Speed / Direction is controlled by a Plus 1 governor w/ Remote
- Tub is hydraulically chain-driven with variable speed and reverse
- Elevator drives from the top with rubber lagged pulley
- Hydraulically raise, lower and swing side to side the discharge elevator
- Trouble-free High-capacity discharge auger
- Highest Capacity, most Durable Grinder available
- Multi-functional Remote Control