



WOOD PU MODEL 4100



You get more than 70 years of hands-on, in-the-field experience in every Mighty Giant we build.

*Durable to Last Generations,
Innovative to Meet Your Diverse Grinding Needs*



402-528-3861



mightygiant@mightygiant.com



www.mightygiant.com



WOOD PU MODEL 4100

	Model 4100
Engine Options	CAT or John Deere Engine w/ extended warranty
Horsepower	Up to 900 HP
Fan	Optional Reversing Fan
Clutch	Twin Disc SP318 or Fluid Coupling
Hammer	3/4" or 1" thick
Number of Hammers	63 Swinging Hammers
Mill	28" x 56"
Mill Bearing Size	3 15/16" Pillow Block
Mill Hammer Pins	6 - 1 1/4" Diameter
Tub Size	10' Wood Tub
Tub Drive	Dual Drive
Elevator Dimensions	24" x 25' Hydraulic Fold Over or 24" x 27' Rigid (Both options swing)
Elevator Drive	Top Drive
Discharge Auger	16" Right Hand Auger
Dimensions	Length: 35' 3" to 37' 6" Width: 11' 4" to 12' 2" Height: 11' 10" to 13'
Weight	Approximately 38,000 pounds

The Mighty Giant Model 4100 is a heavy duty, commercial grinder designed for the Wood Industries. It features a variable speed tub with a Plus One Controller. All tub and elevator functions are remote controlled. A 25' or 27' long, swinging, stacking conveyor for loading trucks, commodity buildings and piles.

The Mighty Giant comes equipped with a CAT or John Deere engine, featuring extended engine warranty coverage.

Standard on every Mighty Giant - from the PTO Model to the Hydrafork - is the hydraulic opening tub for easy access to the mill, hammers and screens - eliminating the need to climb in and out of the tub.

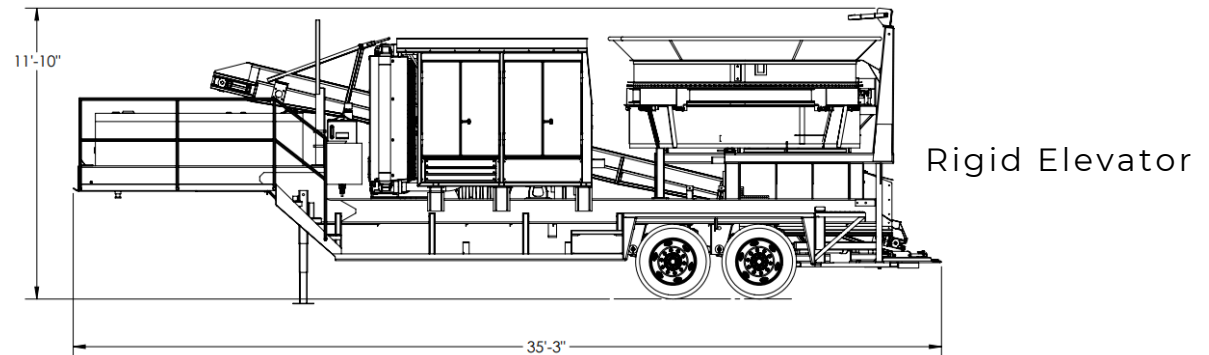
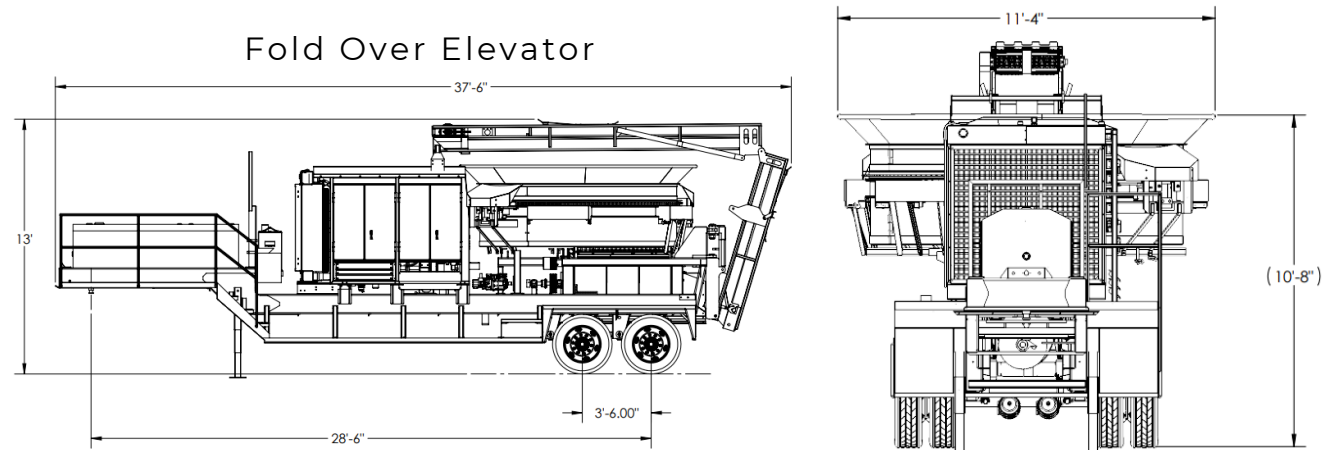

FEATURES

- 25K Air Ride Tandem axle, dual wheel chassis with Tube Frame
- Tub opens hydraulically for servicing and changing screens
- Tub Operation is controlled by a Plus 1 Governor w/ Remote
- Tub is hydraulically chain-driven with variable speed and reverse
- Elevator drives from the top with rubber lagged pulley
- Hydraulically raise & lower discharge elevator
- Trouble-free 16" High-capacity discharge auger
- Multi-function remote control

Manufacturer reserves the right to modify designs, materials and specifications without notice.