



STATIONARY MODEL 2300



*Since
1929*

You get more than 70 years of hands-on, in-the-field experience in every Mighty Giant we build.

***Durable to Last Generations,
Innovative to Meet Your Diverse Grinding Needs***

☎ 402-528-3861

✉ mightygiant@mightygiant.com

🌐 www.mightygiant.com



STATIONARY MODEL 2300

	Model 2300
Mill	26" x 48" with 5" shaft
Mill Bearing Size	3 15/16" Pillow Block
Hammers	3/8" or 1/2"
Number of Hammers	Up to 84 with 360 Degree Swing
Mill Pins	6 pins - 1-1/4" in diameter
Mill Disc	Grain: 1/4" Hay: 3/8"
Mill Base	Tube Construction
Tub Floor and Walls	1/4" Floor, 10ga walls
Tub Drive	Single Drive Hydraulic Motor Drive w/ No. 2100 Heavy Duty, Self Adjusting Chain
Elevator Dimensions	24" x 25' folding and swinging
Elevator Drive	Top drive via hydraulic motor
Discharge Auger	14" Diameter
Transport Dimensions	Length: 22' 5" Width: 11' 4" Height: 12'
Weight	Approximately 18,000 pounds (grinder only) Approximately 23,000 pounds with motor

The Mighty Giant Model 2300 is a heavy duty, commercial stationary grinder built for all your grinding needs. It features a variable speed, hydraulically and electronically driven tub and a hydraulically driven, swinging, stacking, conveyor. (conveyor is optional) Both the tub and elevator are run by remote control for operator convenience.

The Mighty Giant 26" x 48" free swing hammer mill is used for higher production rates and better quality finished product.

Along with the option of operating by either electric or diesel power, the tub can also be replaced with a hopper.

The unit comes with a 14" discharge auger under the mill, which allows trouble free grinding with less mess under the machine. It also has a support frame built onto the machine to make it ready to set into place.

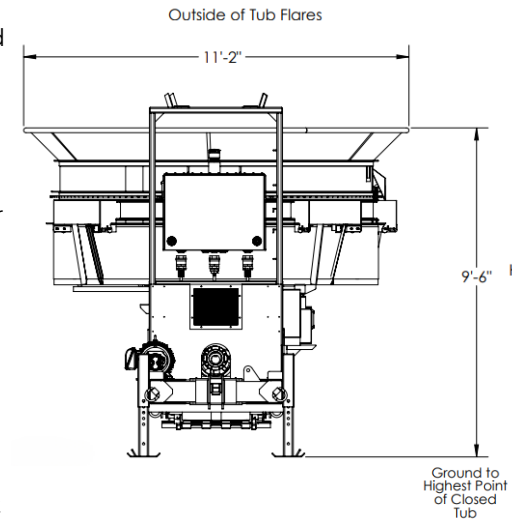

POWER OPTIONS

Electrical: 400 hp, 1800 RPM, 3-Phase, 60 hertz, 460 Volts Motor - 15 hp, Soft Start IN 3R Control Panel/Enclosure - 15 hp 1800 254T TEFC Premium Efficient WE Motor for Auxiliary Hydraulics

Diesel: CAT C9.3B 415 hp Tier4F (DEF) w/214 Rear Clutch - CAT C9.3B 415 hp Tier4F (DEF) w/LPT019 Fluid Coupler

FEATURES

- Tub opens hydraulically for servicing and changing screens
- Tub Operation is controlled by a Plus 1 governor
- Tub is hydraulically chain-driven with variable speed and reverse
- Elevator drives from the top with rubber lagged pulley
- Hydraulically raise, lower, swing and fold the discharge elevator
- Trouble-free 14" High-capacity discharge auger
- Capable of Grinding any type of Forage or Grain
- Highest Capacity, most Durable PTO Grinder available
- Remote Control Standard for Tub Start/Stop elevator Raise/Lower/Swing

